

**DATA SHEET**  
**LLINK™-09 for MOPA Fiber Lasers with Adjustable Pulse width**

---

**NEWSON NV**

## Table of Contents

<b>1</b>	<b>CONNECTIONS LLINK™</b> .....	<b>3</b>
1.1	COMPATIBILITY .....	3
1.2	DIMENSIONS .....	3
1.3	INTERNAL SCHEME .....	4
1.4	POWER SUPPLY .....	4
1.5	CONNECTION EXAMPLES CUA - LLINK™ - 09 .....	5
1.6	PULSE WIDTH CONTROL .....	6
<b>2</b>	<b>DLL LIBRARY FUNCTIONS</b> .....	<b>7</b>
2.1	LLINK COMMANDS .....	7

## 1 CONNECTIONS LLINK™

The LLINK™ hardware provides an easy interface to lasers. A **single twisted pair** is the only connection between a CUA-control unit and the laser.

LLINK™-09 is built for MOPA fiber lasers with I2C serial protocol extension to set the pulse width.

### 1.1 COMPATIBILITY

LLINK™-09 hardware supports following laser sources:

- YDFLP 20/30 Fiber Laser source with Adjustable Pulse Width (Shenzhen JPT Opto-Electronics)
- MFPT-10/20 Fiber Laser source with Adjustable Pulse Width (Maxphotonics)

### 1.2 DIMENSIONS

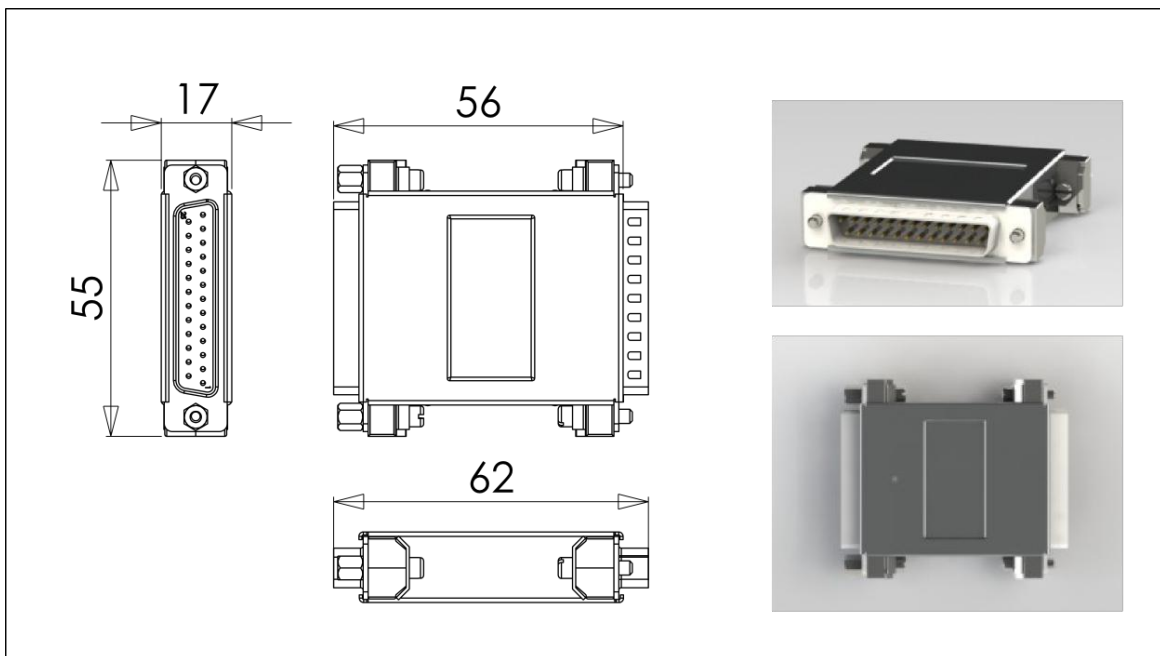

All dimensions are in mm.

The LLINK™ hardware has 2 connector sides.

One side is marked, Laser and should be directly plugged into the control connector of the laser.

The other side is marked CUA.

### 1.3 INTERNAL SCHEME

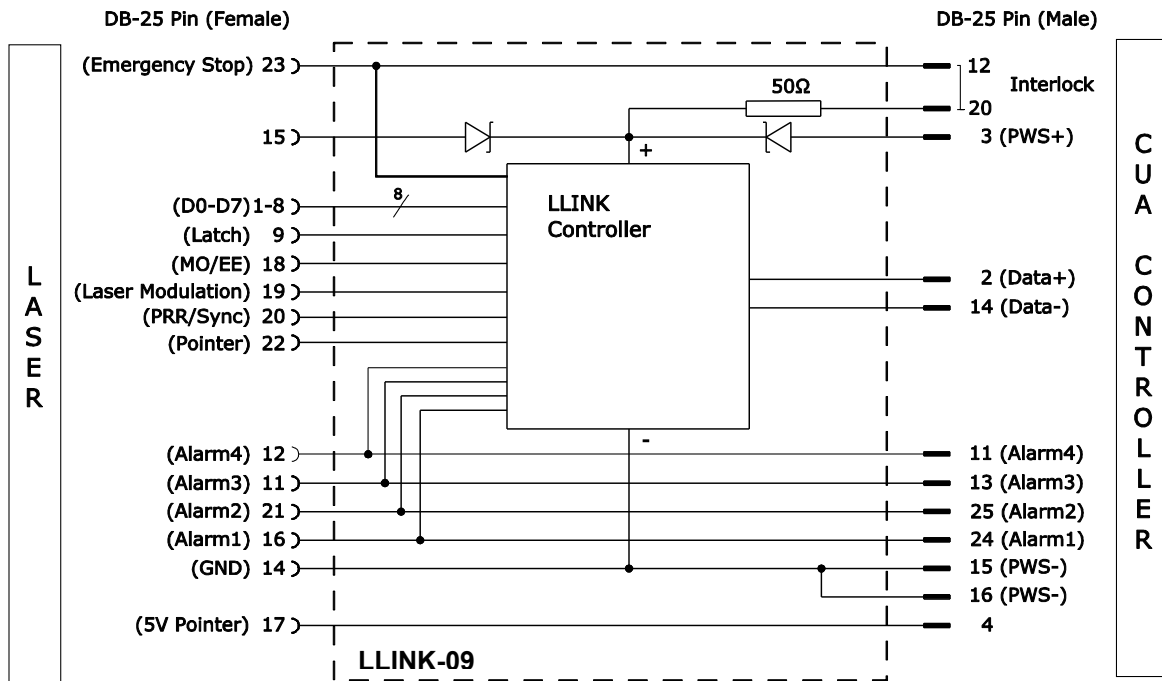

### 1.4 POWER SUPPLY

LLINK™ systems need to be powered by a 5V DC power supply. Due to the specification of the laser, this power supply needs to be floating (not connected to EARTH). The grounding of the power supply is done inside the laser. Some laser interface types have a 5V DC power output which can be used as power supply for the LLINK™. These laser types don't need an external powering for the device. (5V DC power is then supplied on pin15).

#### WARNING

The LLINK™ is not protected against reverse polarity or overvoltage. Reverse polarisation or overvoltage will damage the system.

In order to minimize cost, one can use the 5V DC output of the CUA board. In order to be in compliance with the directives of the laser, the 12V power supply of the CUA needs to be floating. The connected motors and the CUA control board will be connected to earth through the Laser.

## 1.5 CONNECTION EXAMPLES CUA - LLINK™ - 09

### 1.5.1 Connect LLINK™ using external 5V, 100mA power supply

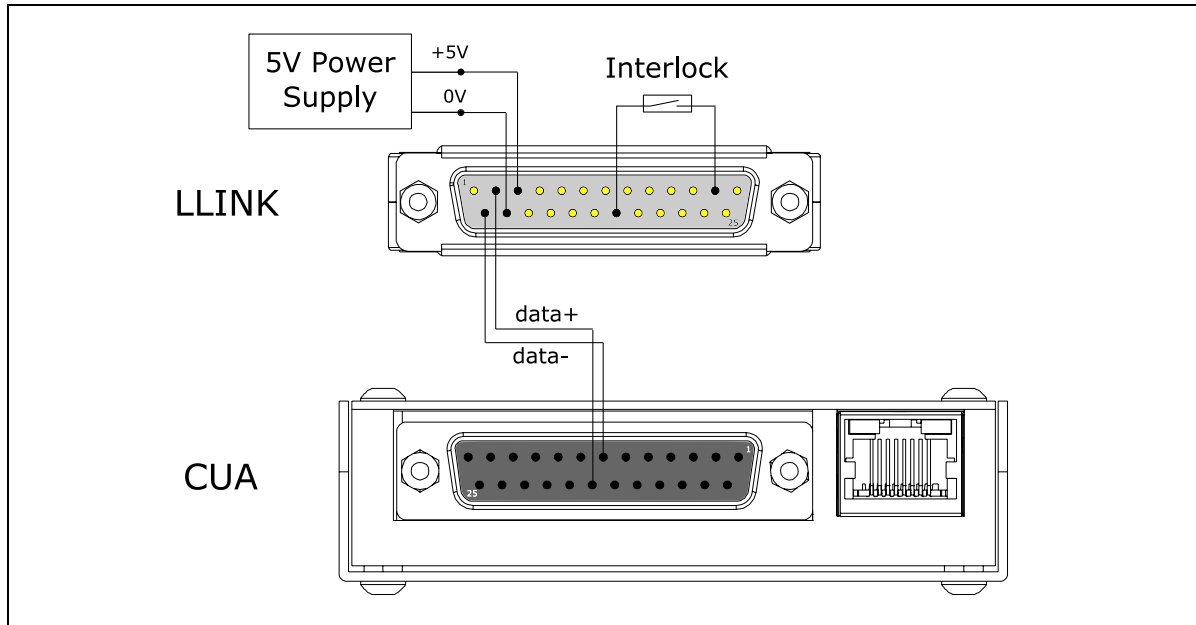

### 1.5.2 Connect LLINK™ using 5V power supply output of CUA

**Remark:** In this setup the CUA card needs to be floating (not connected to EARTH).

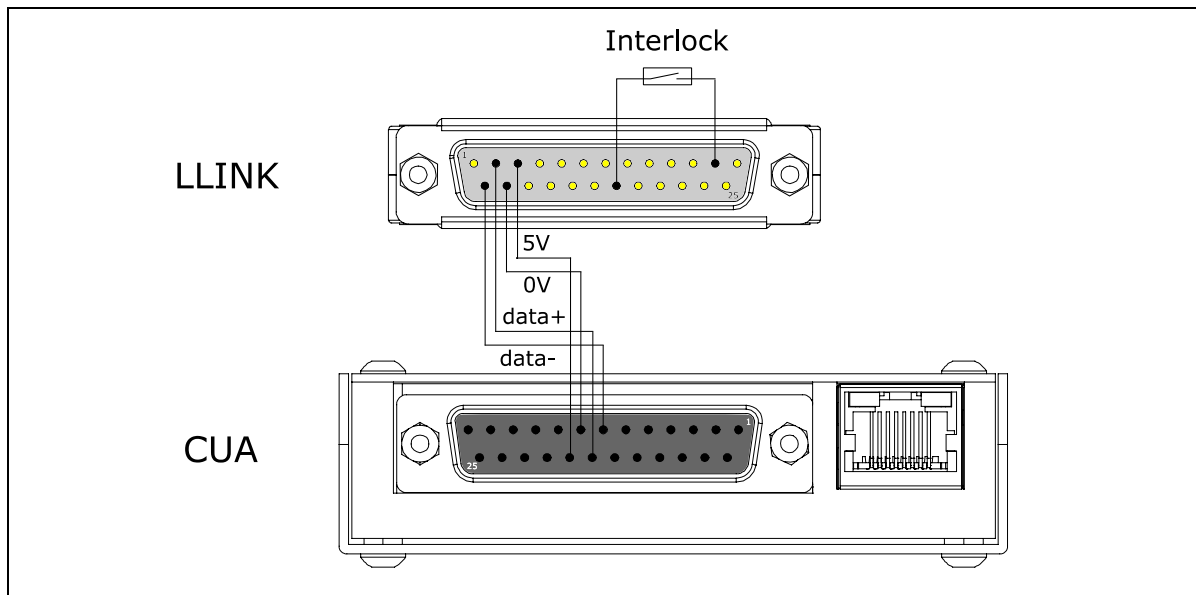

### 1.5.3 Connect LLINK™ using 5V power output of laser (verify laser interface)

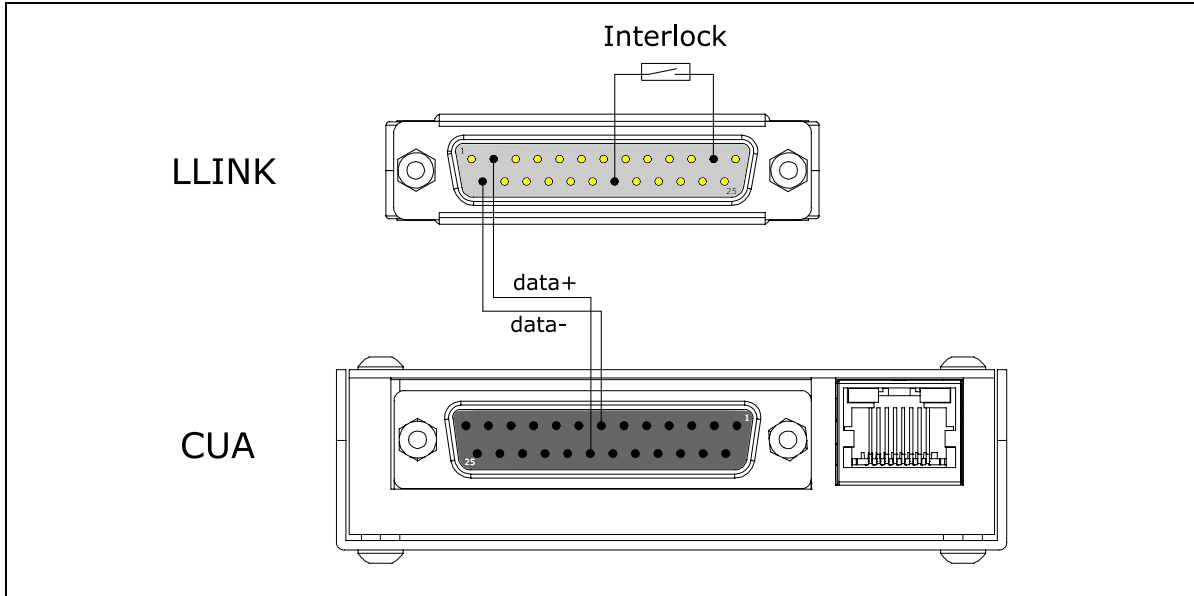

## 1.6 PULSE WIDTH CONTROL

LLink-09 supports extended pulse width control over an I2C protocol

Pin number	Name [Basic Control]	Description
2	Serial Input [D1]	Serial input, stable on serial clock rising edge
3	Serial Clock [D2]	Serial digital clock, 10 kHz
22	Control Enable [Pointer]	High: enable D1/D2 to control the pulse width

The fiber laser instruction send by the LLink-09 contains 4 bytes and has following format:

0xA5	Header	Fixed
0x01	Instruction Code	Fixed
0x00	PulseWidth High 8 bits	Variable/Fixed(*)
0xC8	PulseWidth Low 8 bits	Variable

(\*) Extended pulse widths

LLink devices with Serial > 35612 support pulsewidth values > 255 ns

For example 2024 is the decimal number of 0x07DE, representing the pulse duration of 2024 ns

To achieve 2024 ns pulse width call following sequence:

```
rtSetLaserLink(7, 7) // 0x07 is the decimal number 7
rtSetLaserLink(6, 222) // 0xDE is the decimal number 222
```

Older LLink devices or only calling rtSetLaserLink(6, val) assumes high order byte value 0x00

For example 140 is the decimal number of 0x008C, representing the pulse duration 140 ns

To achieve 140 ns pulse width call following:

```
rtSetLaserLink(6, 140) // 0x8C is the decimal number 140
```

## 2 DLL LIBRARY FUNCTIONS

The LLINK™ hardware provides an easy interface to MOPA lasers. A single twisted pair is the only connection between a CUA-control unit and the laser. All commands send to the LLINK™ are executed immediately. It's the responsibility of the machine application to verify needed timing and sequences to comply with the laser datasheet.

```
rtSetLaserLink(cmd,value)
rtGetLaserLink(cmd,&value)
```

In next example script EE/MO is activated. A sleep of 8 ms is added to comply with the laser pump charging time. Then the PRR/SYNC is set to a 25 kHz signal with a dutycycle of 50%. The pulse width is set to 100ns using a fiber laser serial instruction. Finally the power is set to 50%;

```
rtListOpen(1)
rtSetLaserLink(3,1)
rtSleep(8000)
rtSetLaserLink(1,25)
rtSetLaserLink(2,128)
rtSetLaserLink(6,100)
rtSetLaserLink(0,128)
rtListClose()
```

### 2.1 LLINK COMMANDS

#### Power Setting

```
command: rtSetLaserLink(0,value)
action:
1: copies value to pin 1..8 connector (power setting)
2: wait 1.8 µsec
3: set pin 9 (latch setting in laser)
4: wait 1.8 µsec
5: reset pin 9
```

#### Frequency Setting

```
command: rtSetLaserLink(1,value)
action: sets the Pulse Repetition rate. (pin 20)
value is frequency in KHz (range 1..255)
```

#### DutyCycle

```
command: rtSetLaserLink(2,value)
action: sets the duty cycle of Pulse Repetition rate. (pin 20)
value 0 = 0%
value 255 = 100%
```

**Emission Enable (EE) / Master Oscillator (MO)**

```
command: rtSetLaserLink(3,value)
action
if bit0 of value is set, set pin 18 (EE/MO on)
if bit0 of value is cleared, reset pin 18 (EE/MO off)
```

NOTE: Laser Modulation Signal (pin 19) is only generated when EE/MO is enabled.

**Guide Laser**

```
command: rtSetLaserLink(4,value)
action
if bit0 of value is set, set pin 22 (Guide Laser on)
if bit0 of value is cleared, reset pin 22 (Guide Laser off)
```

**Frequency Setting (10KHz steps)**

```
command: rtSetLaserLink(5,value)
action: sets the Pulse Repetition rate. (pin 20)
value is frequency in 10KHz steps (range 1..255)
```

**Pulse Width control**

```
command: rtSetLaserLink(6,value)
action: sends PulsWidth serial input instruction to fiber laser (I2C protocol)
1: set pin 22 (Guide Laser / Pulse Width Control Enabled)
2: wait 10 µs
3: send serial instruction through pin2, meanwhile send 10kHz clock signal through pin3
4: wait 10 µs
5: reset pin 22 (Guide Laser / Pulse Width Control Disabled)
Value is expressed in ns. Check laser datasheet for supported values (range 1..255)
For values > 255 precede command
```

**Pulse Width control (extended pulse width)**

```
command: rtSetLaserLink(7,value)
action: sets the high order byte for pulse width control as a pre-amble for
rtSetLaserLink(6, value). rtSetLaserLink(6, value) will reset the high order byte back to
0x00; (supported by LLink devices with serial > 35612, see also 1.6 Pulse Width control)
```

**Query Laser Status bits**

```
command: rtGetLaserLink(1,&value)
action: samples pin 11, 12, 16, 18, 19, 21, 22 and 23 status.
Bit0 of value indicates state of pin 16 (Alarm1)
Bit1 of value indicates state of pin 21 (Alarm2)
Bit2 of value indicates state of pin 11 (Alarm3)
Bit3 of value indicates state of pin 12 (Alarm4)
Bit4 of value indicates state of pin 23 (Emergency Stop)
Bit5 of value indicates state of pin 18 (MO/EE)
Bit6 of value indicates state of pin 19 (Laser Modulation)
Bit7 of value indicates state of pin 22 (Pointer)
```

**Query LaserLink Type**

```
command: rtGetLaserLink(127,&value)
value 0x09: interface LLINK - 09
```